

1921.--.89

Description Robinet 4 voies à encastrer
 Vierwegskraan, inbouw
 Concealed fourway diverter

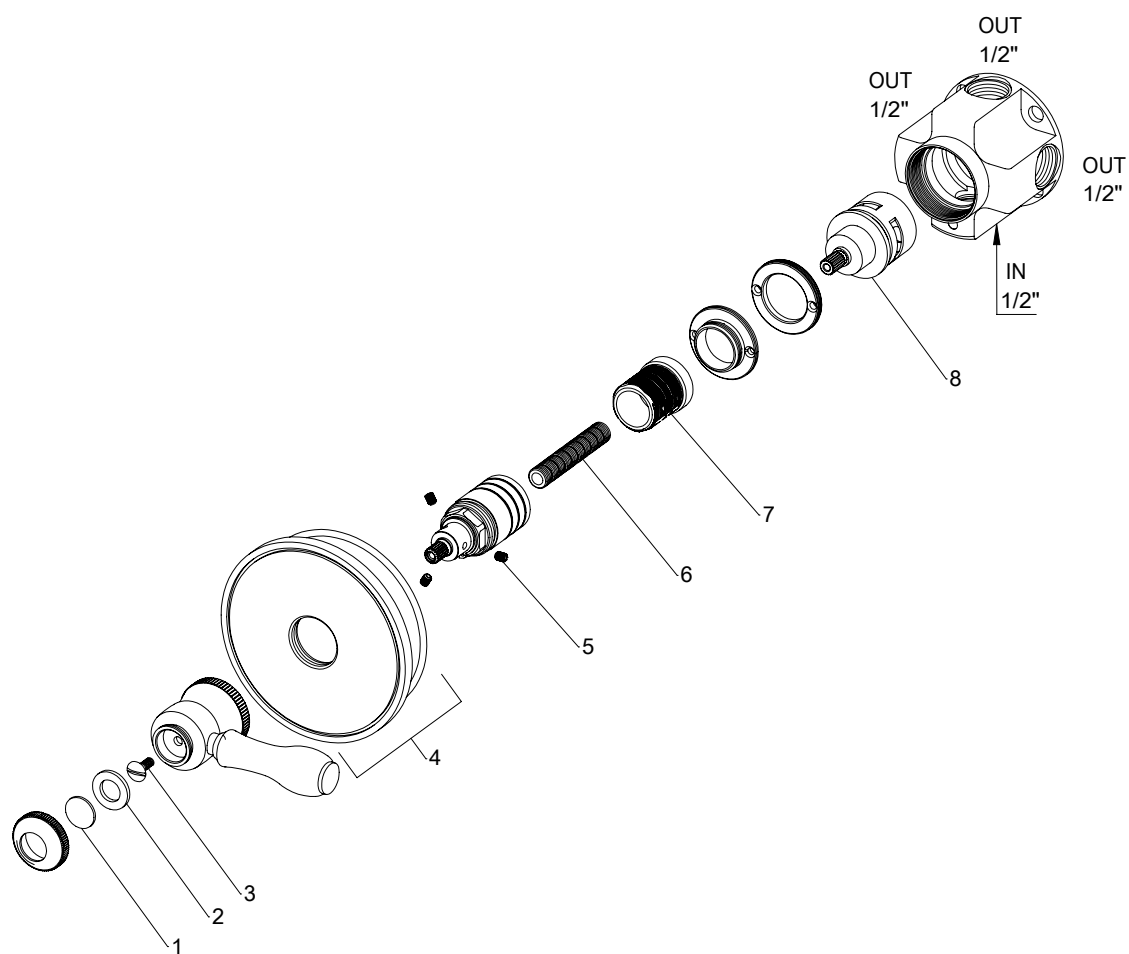

- FR** Instructions de montage et titre de garantie
- NL** Montagevoorschrift en garantiebewijs
- GB** Note of assembly and guarantee voucher



Technical Data Sheet

Weight : 1,7 kg



Internal mechanism : Ceramic valve

Technical drawing

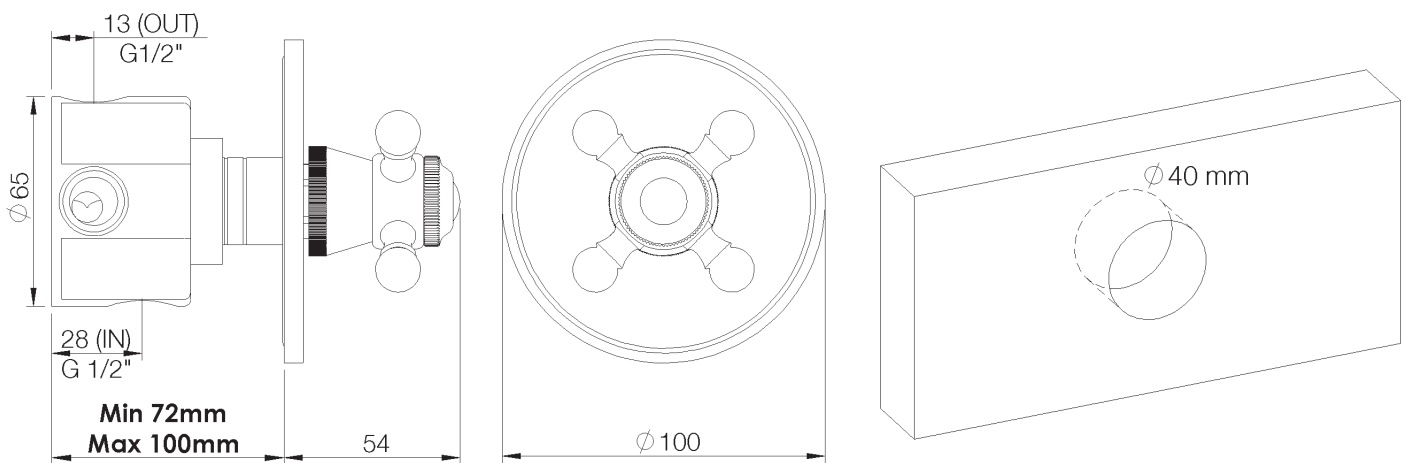

RA2.V01

Matériel fourni

Geleverd materiaal

Included material

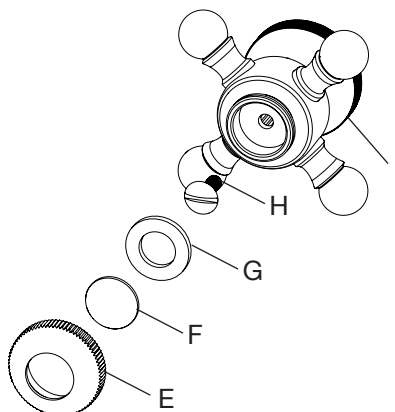
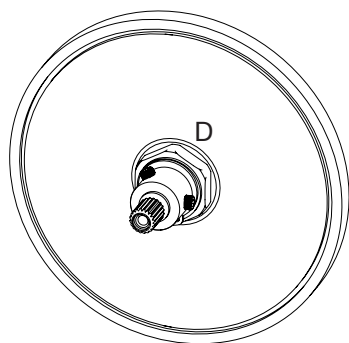
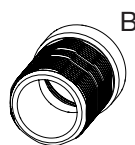
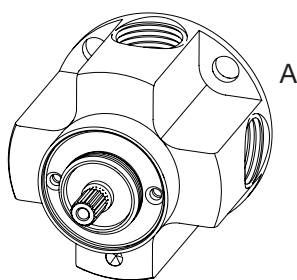
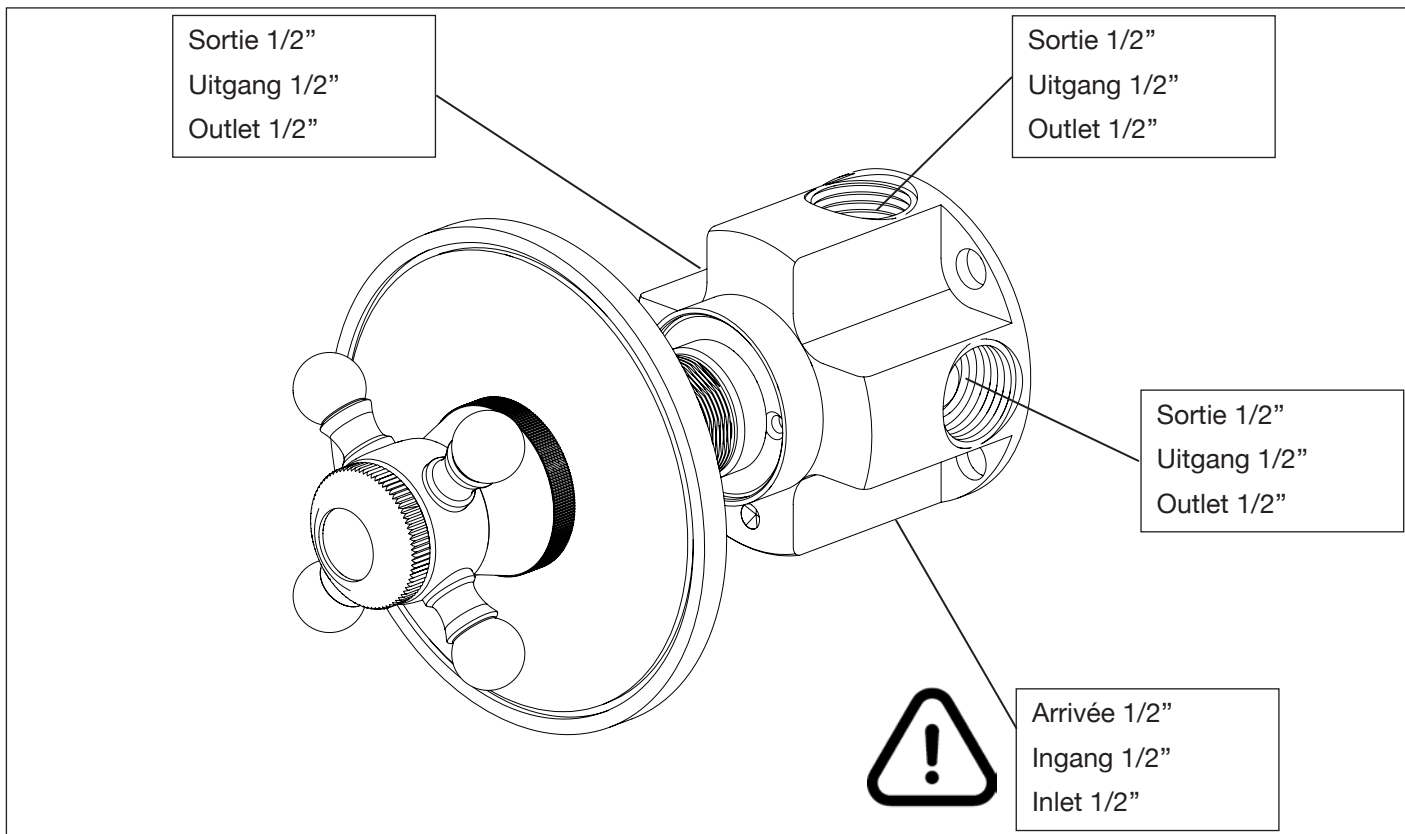

Pour le montage, nous vous recommandons de respecter rigoureusement le sens des flèches (sens de circulation de l'eau, donc vers point de sortie).

Inverser les entrées avec les sorties endommage irrémédiablement les mécanismes à disques ceramiques et rend la garantie inapplicable.

En cas de doute, n'hésitez pas à nous contacter.

Voor de montage van het inbouwgedeelte van de stopkraan moet u er ten stelligste rekening mee houden dat de pijl steeds in de richting van de waterstroom wordt geplaatst (dus richting uitgang).

Het omwisselen van deze aansluiting heeft tot gevolg dat u de keramische binnenwerken onherroepelijk beschadigd en uw garantie vervalt.

Neem contact met ons op bij twijfels of vragen hieromtrent.

For the assembling, we recommend to follow the arrows (circulation of the water to the outlet).

Inversion of inlet and outlet of the water may cause irreversible dammages to the ceramic disks, and cancels your guarantee.

Don't hesitate to contact us should you have any question.

RVB sa Boulevard Industriel 137 B-1070 Bruxelles Belgique

Tel: +32 (0)2 376 00 30 - Fax: +32 (0)2 332 08 54 - info@rvb.be - www.rvb.be

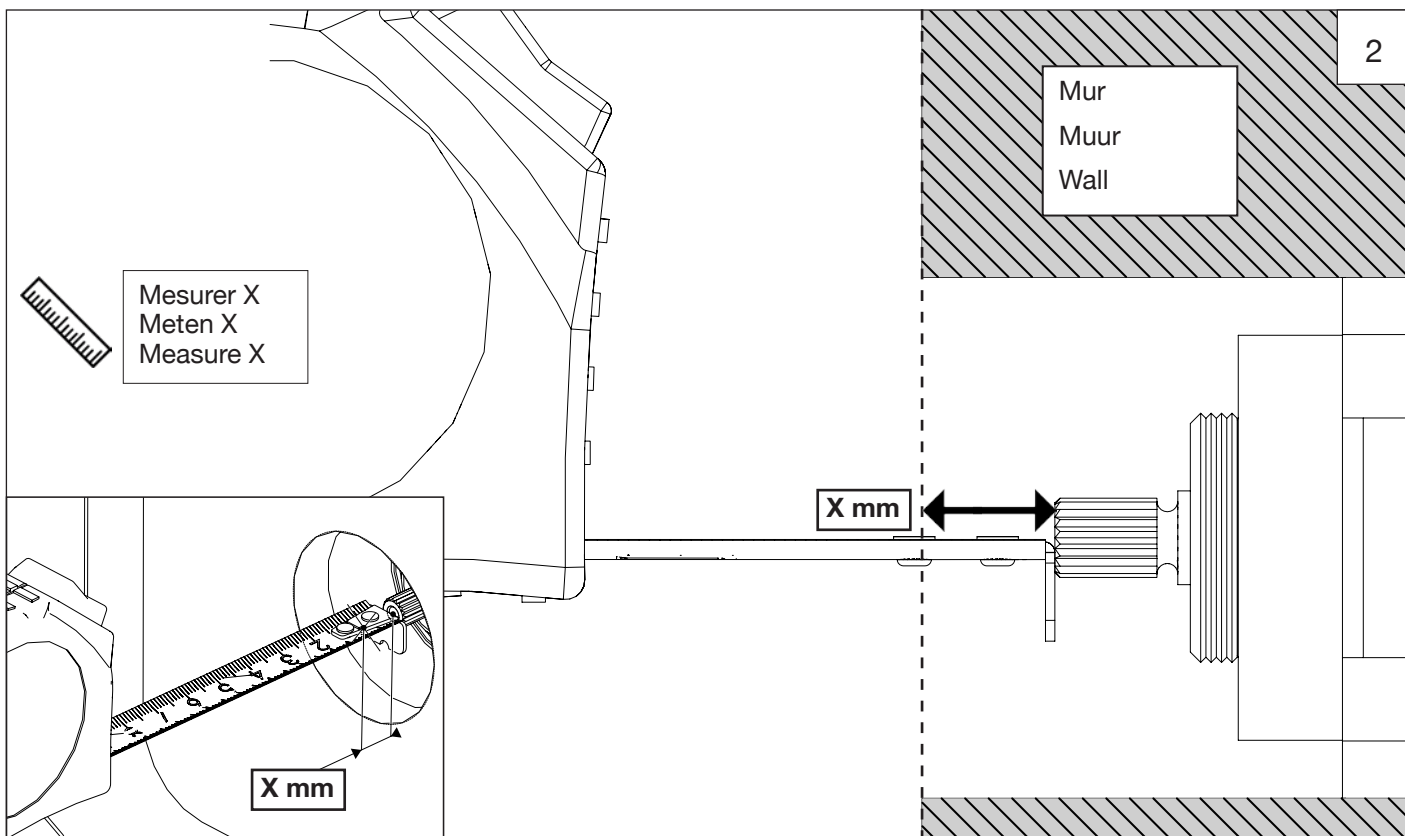
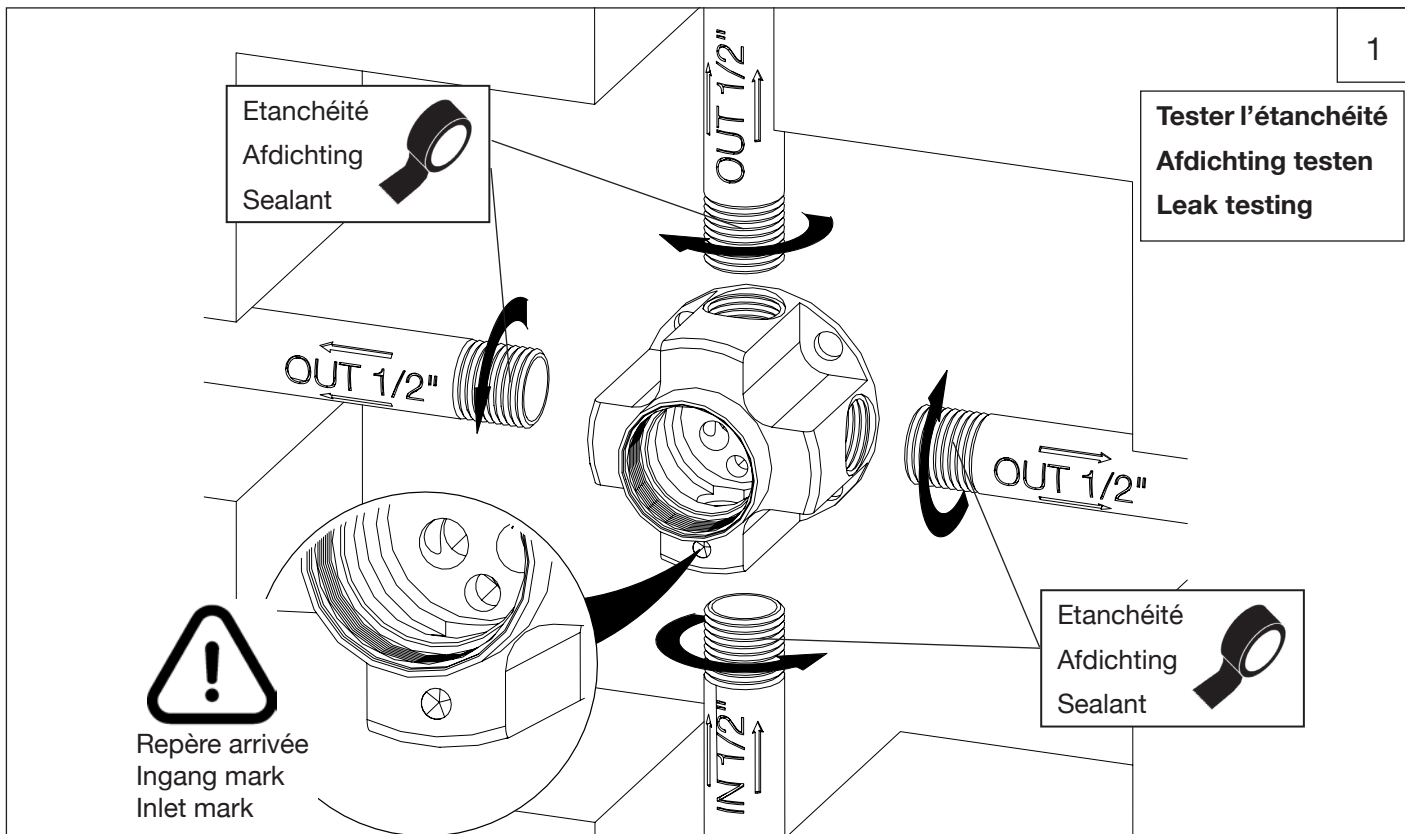

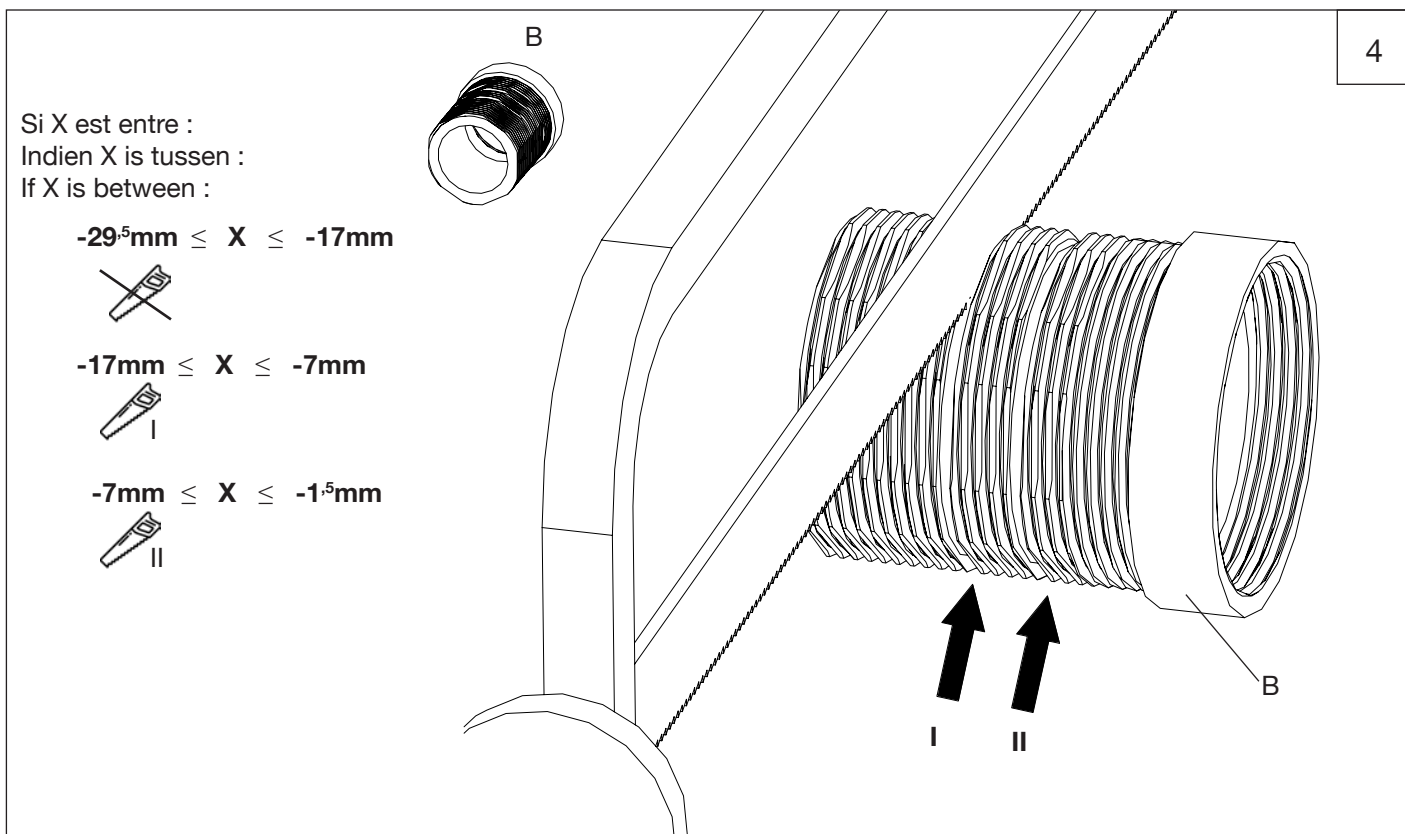
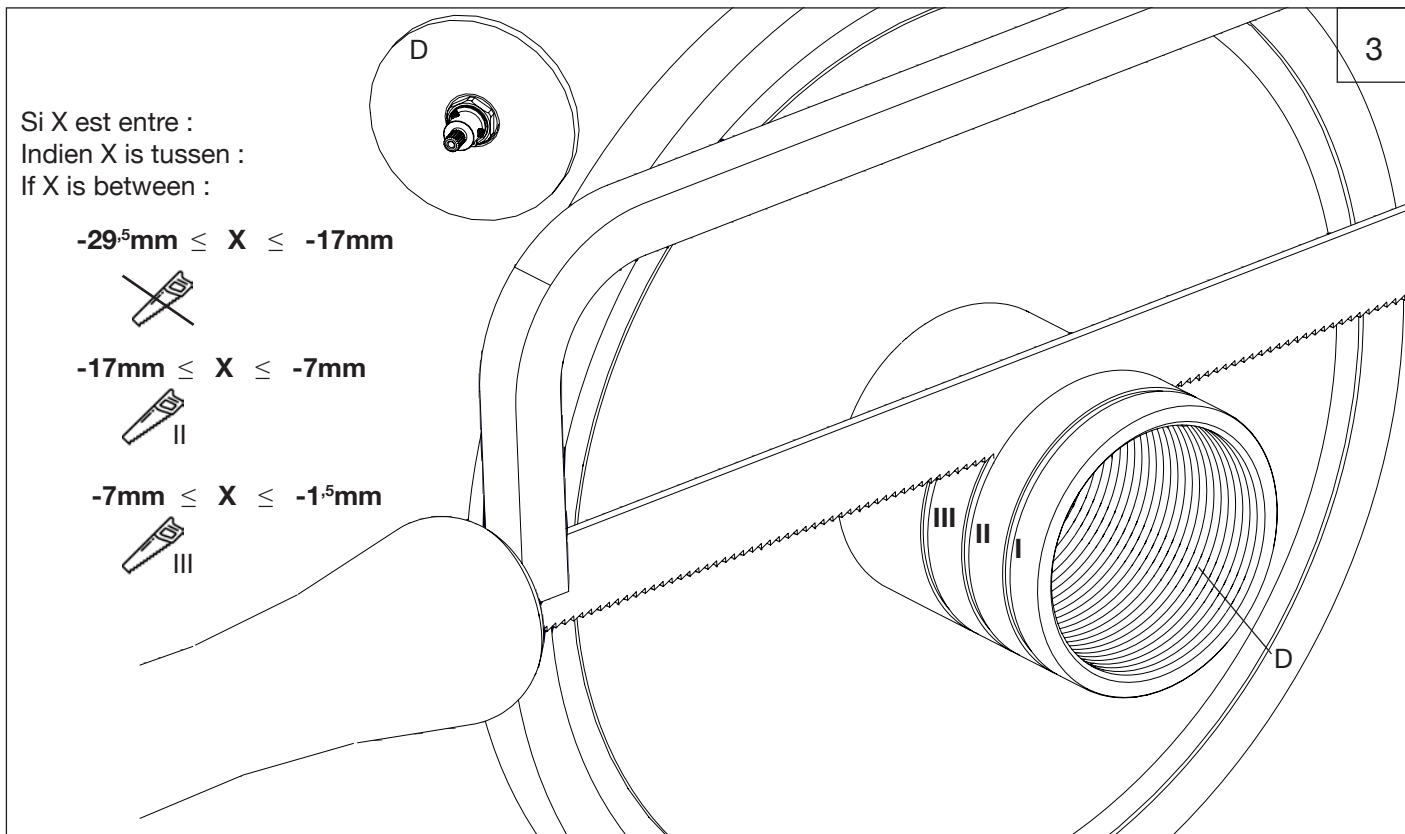

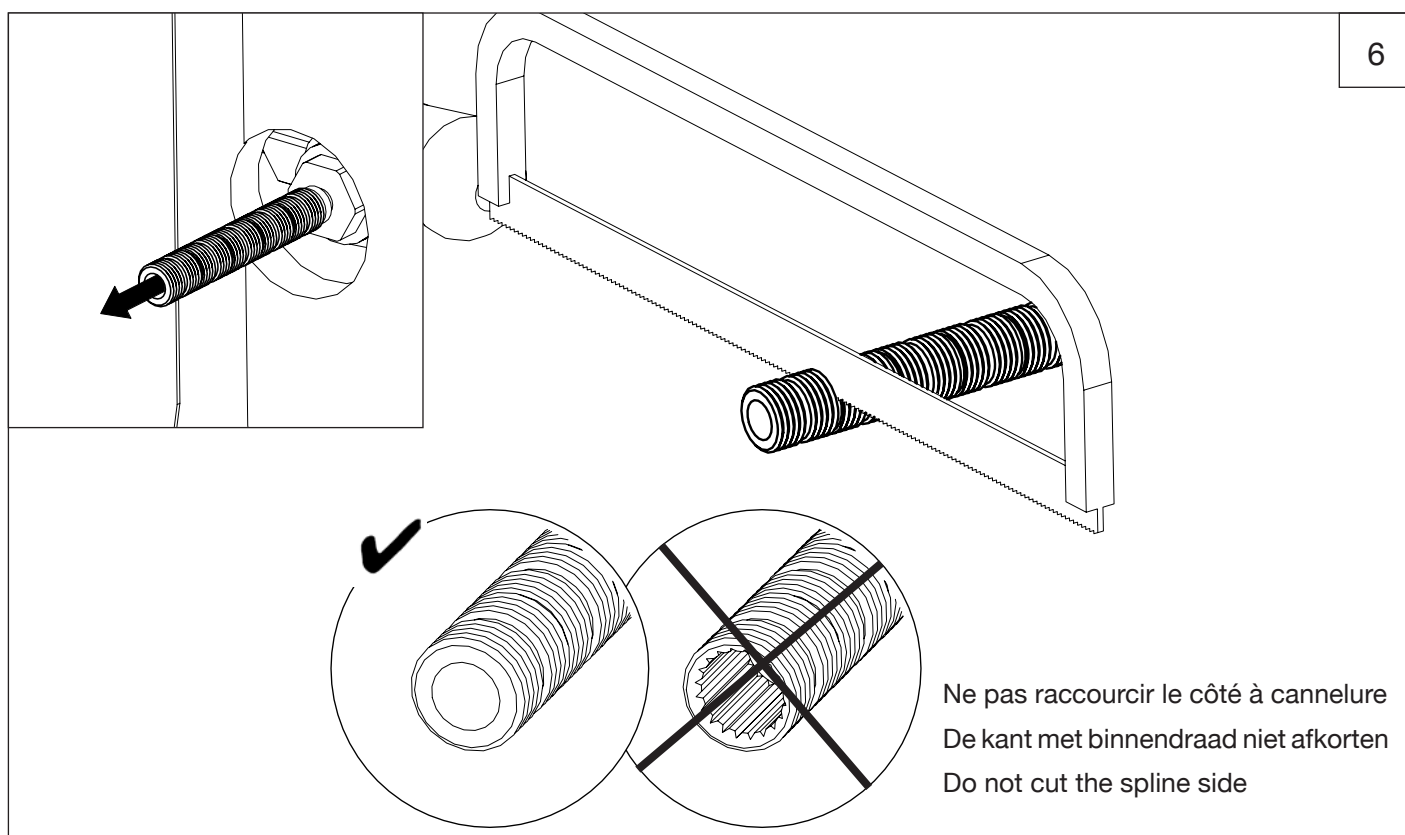
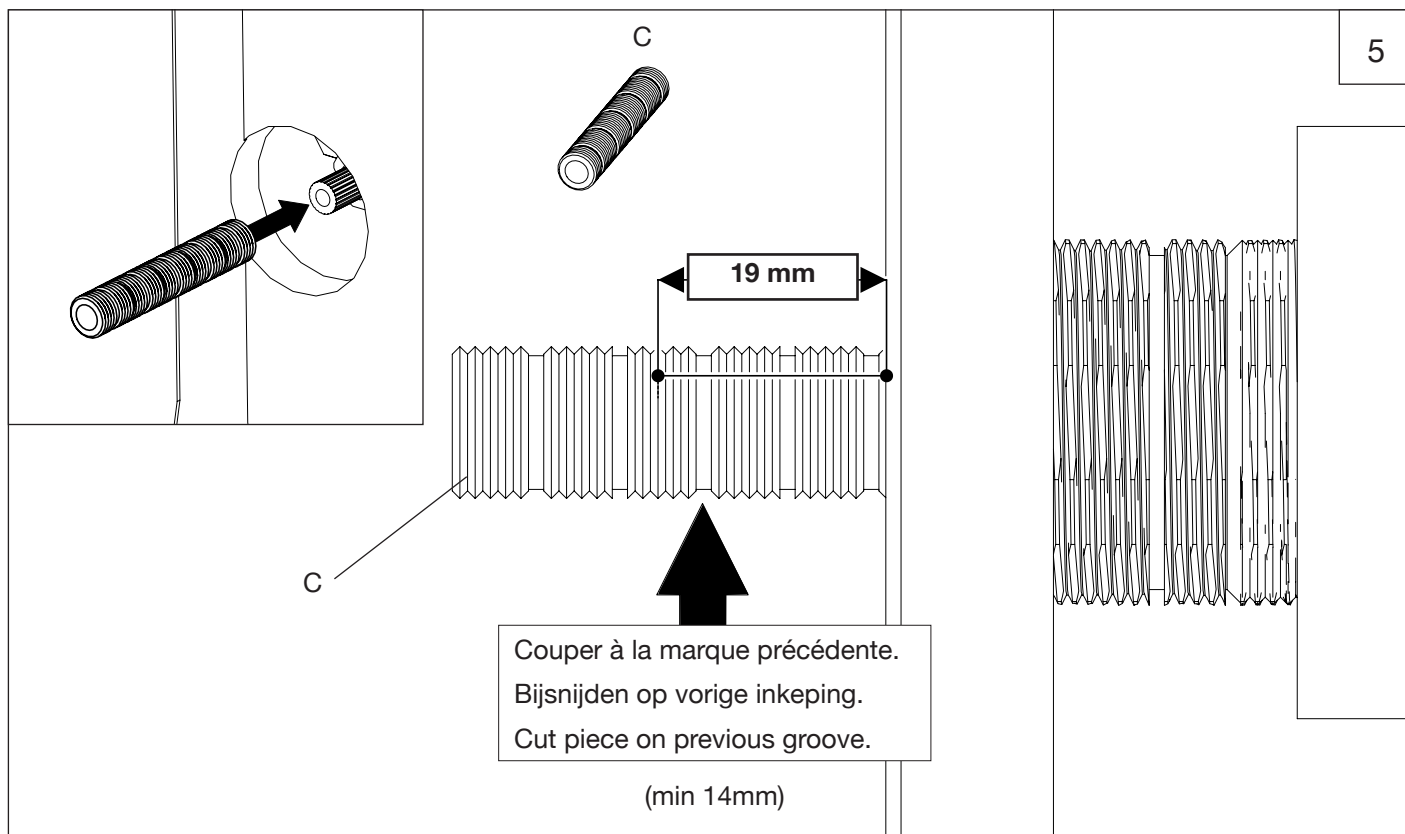

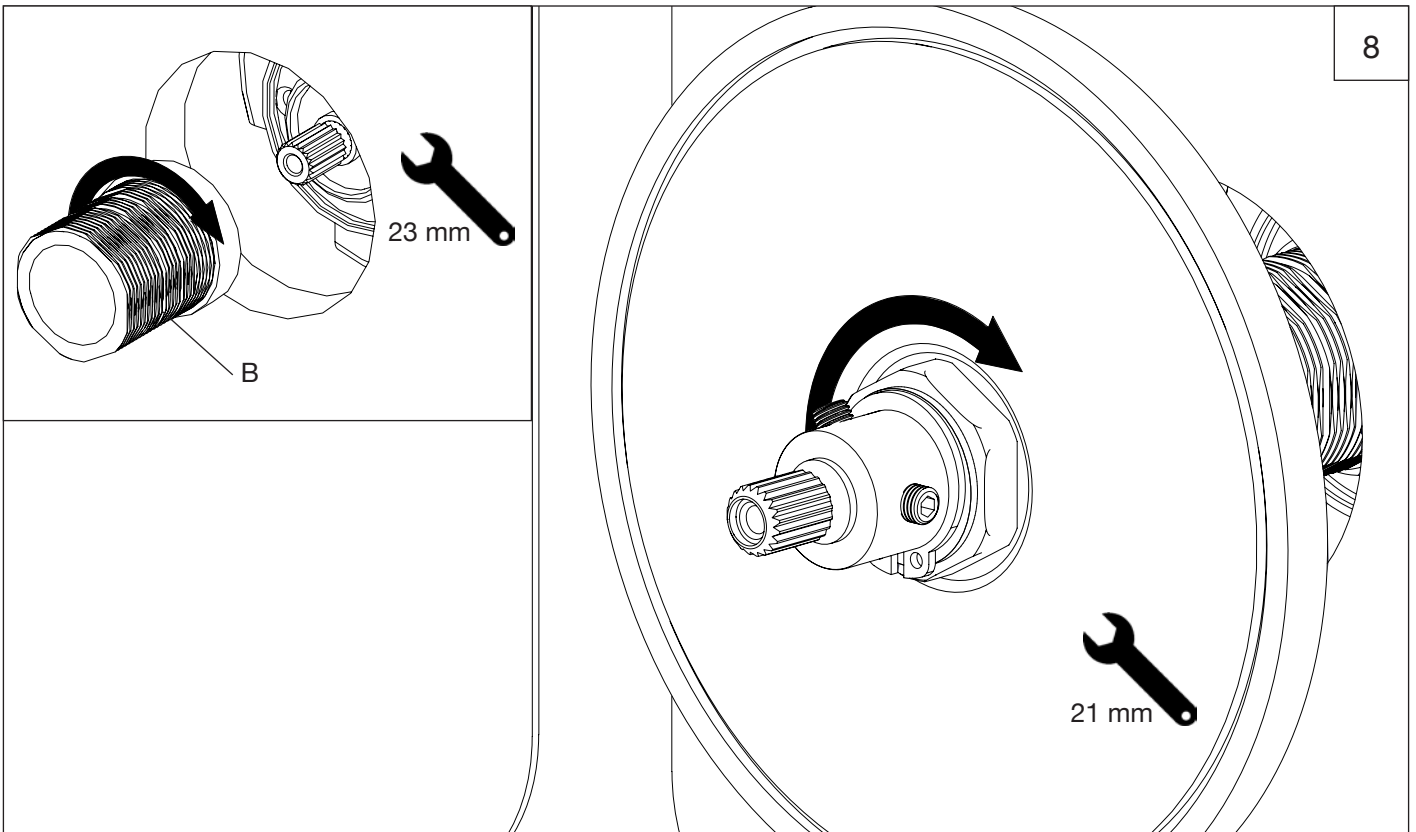
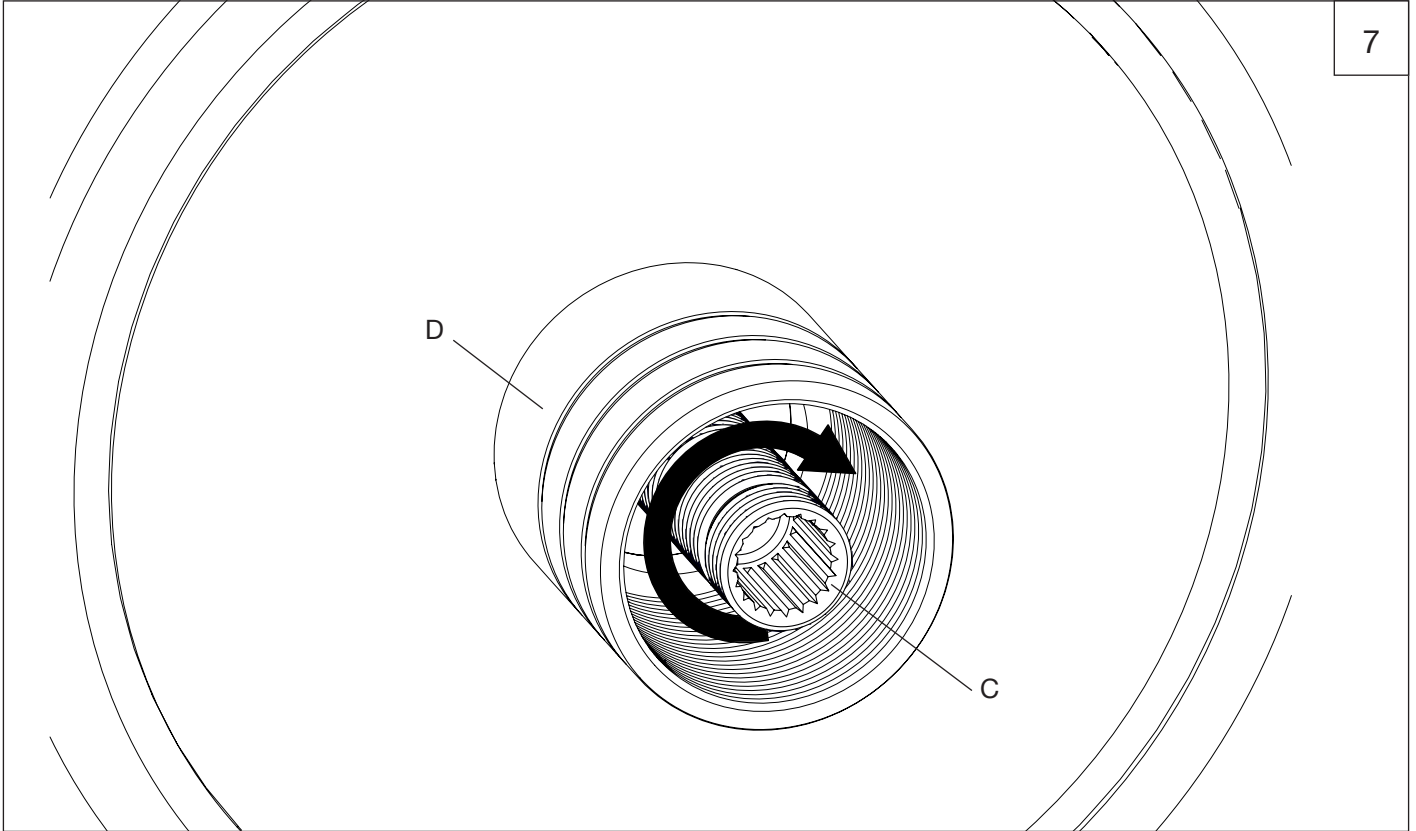

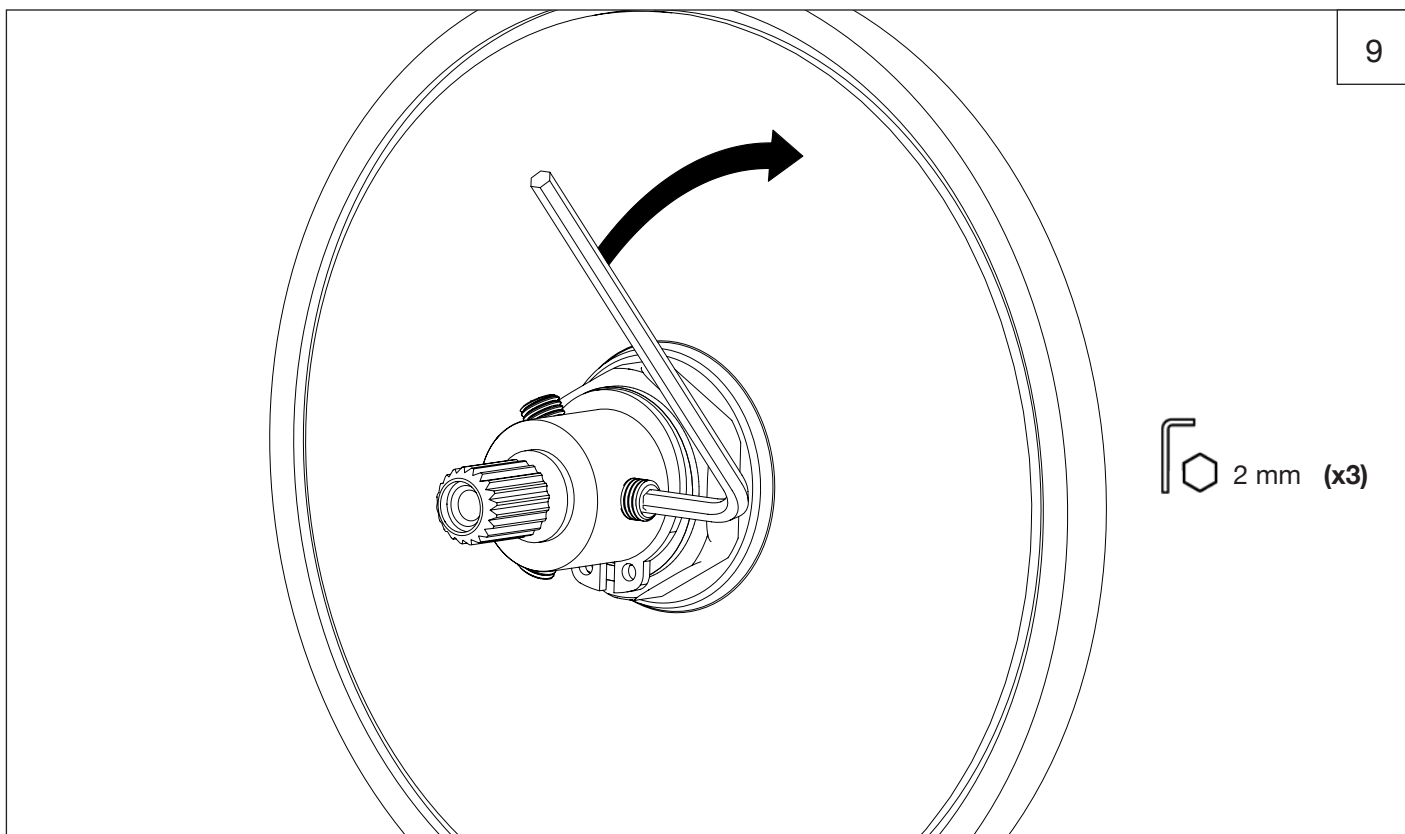
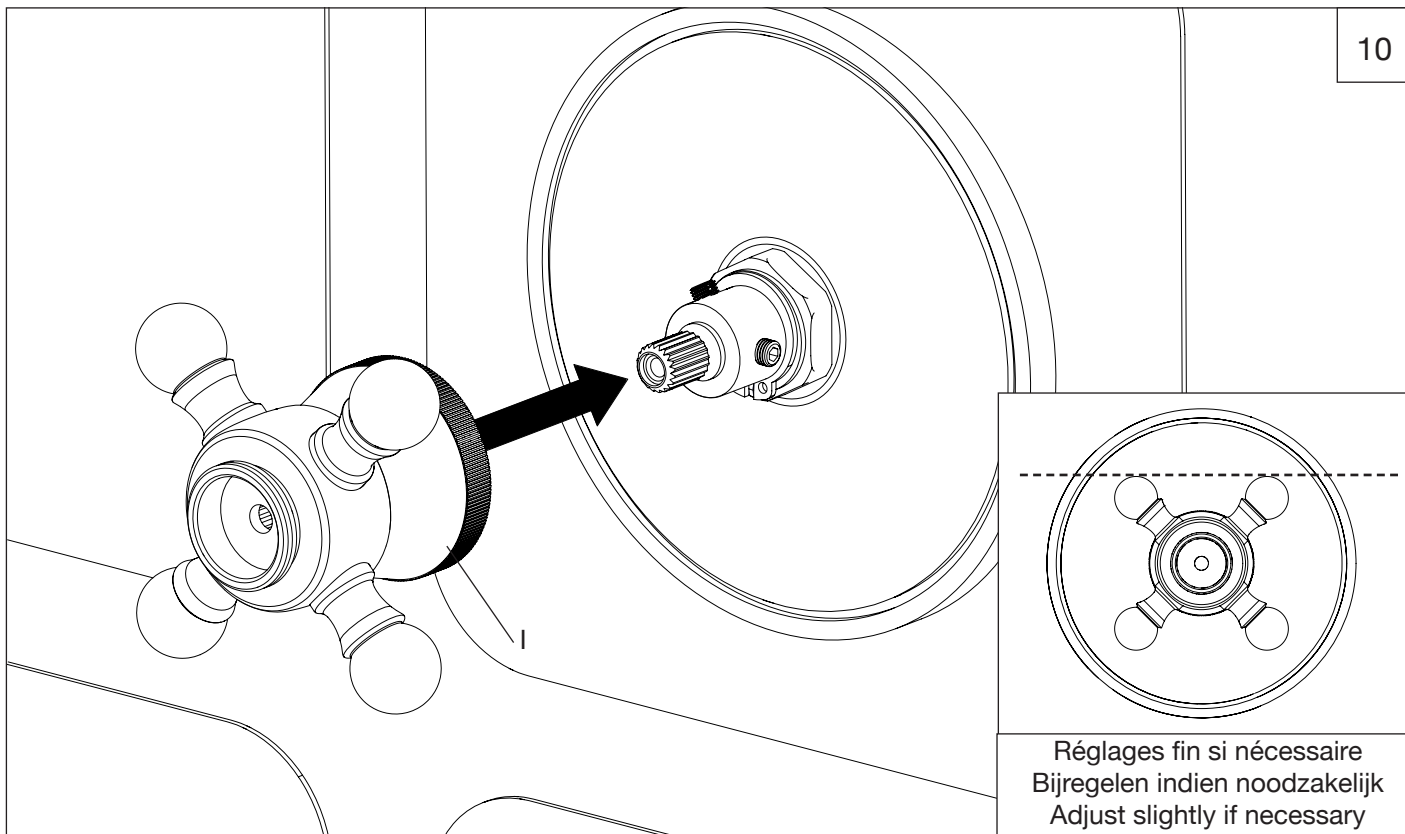

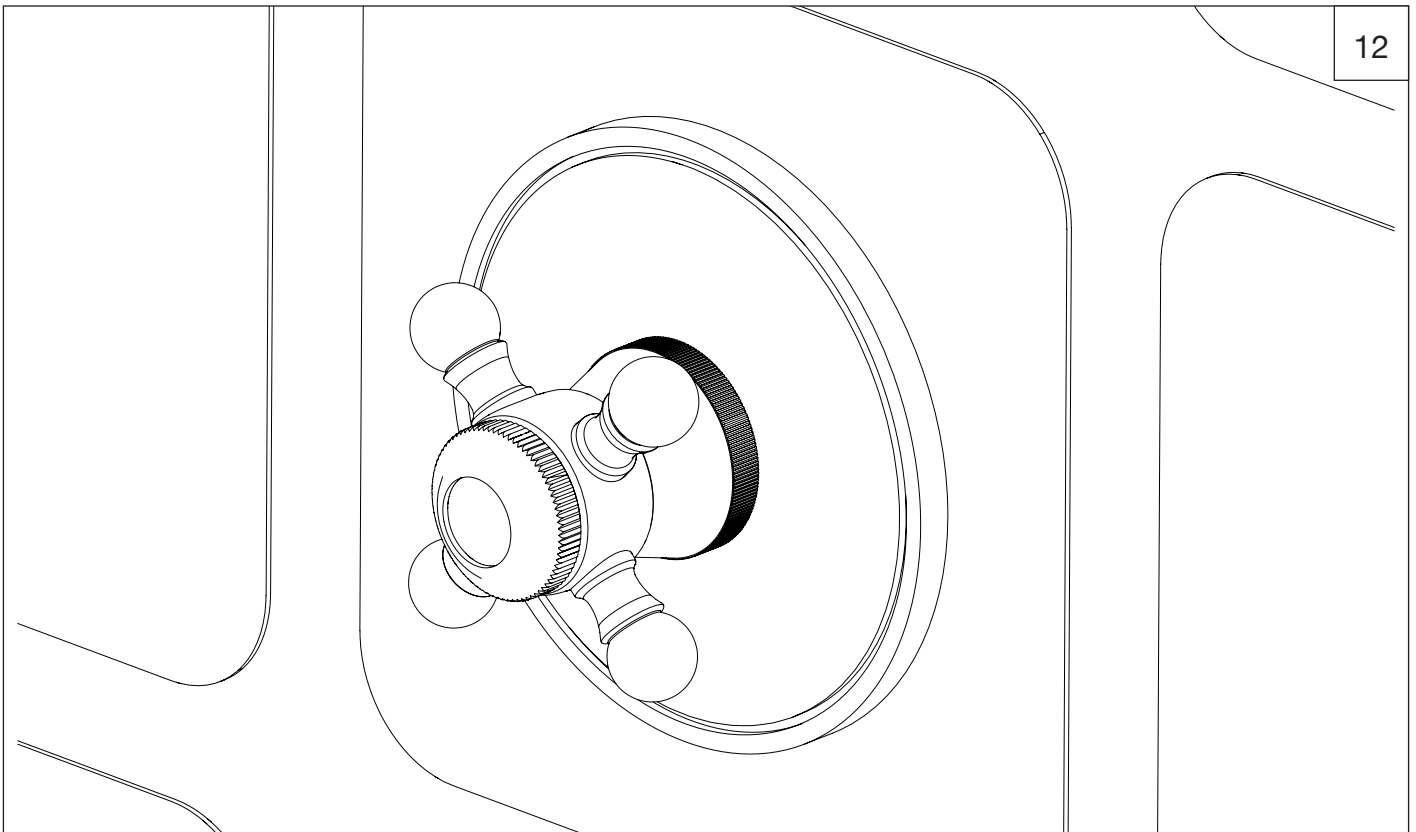
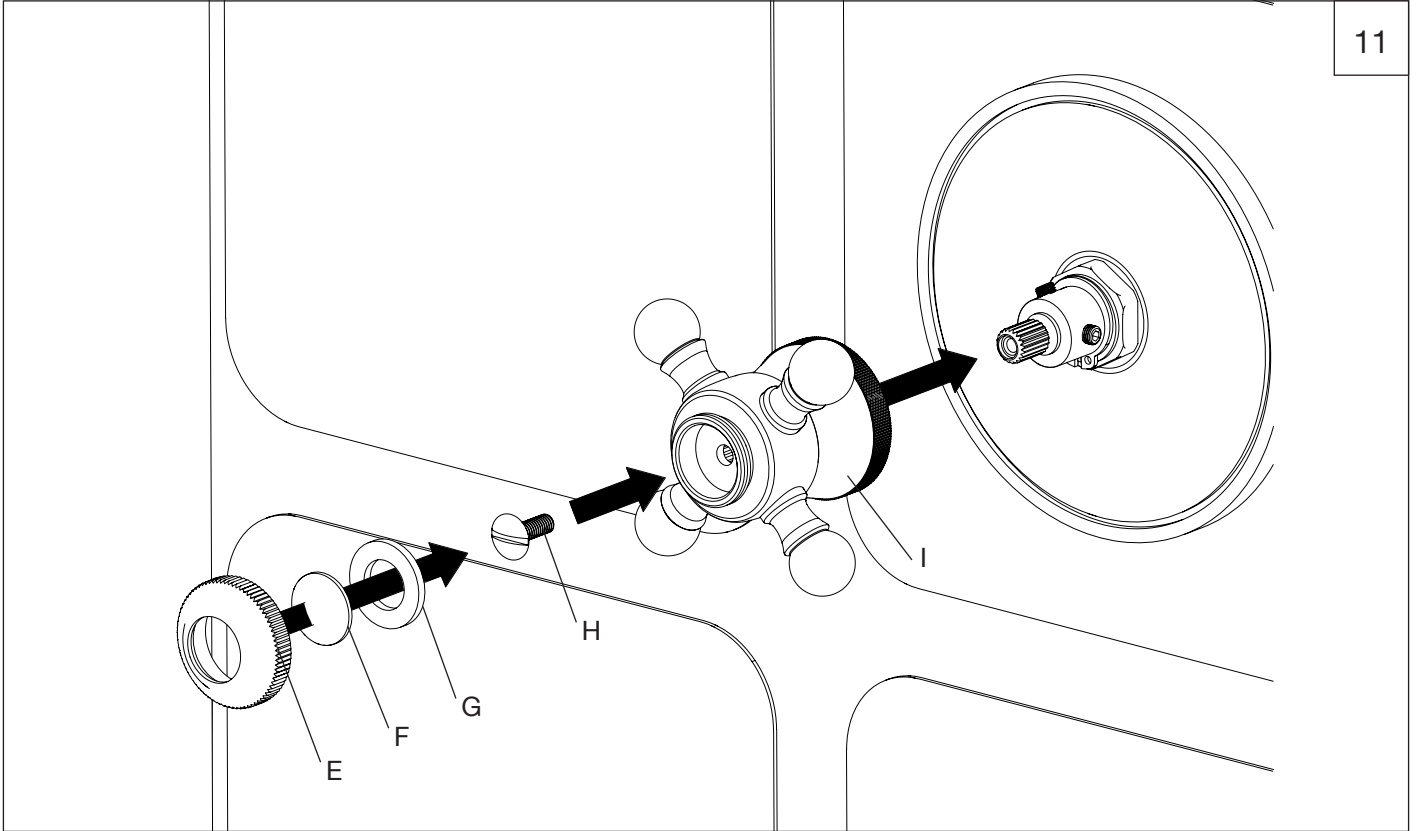

Garantie

Garantie

Guarantee

F Votre titre de garantie repris sur la présente notice de montage ainsi que votre facture d'achat sont nécessaires pour revendiquer l'application de la garantie.

Conservez-les soigneusement. Voyez les conditions de garantie dans le folder «Entretien et Garantie des produits».

NL Om uw waarborg tot garantie te kunnen opeisen, is het noodzakelijk uw aankoopfactuur samen met uw garantiebewijs zorgvuldig te bewaren. Zie de garantie-voorwaarden in de folder «Onderhoud en waarborg van de producten».

GB Your guarantee voucher as your purchase invoice are necessary to claim the application of the guarantee. Preserve them carefully. You can find the guarantee conditions in the folder «Product Care and Guarantee».

1921.--.89	
------------	--